

# Types of Analyses

- Single Collector
  - Uses only one collector or detector
  - This is the case with a Daly or EM
- Advantages:
  - Need only one detector
  - Peaks can always be perfectly centered in detector
  - Can ignore amplifier gain and cup efficiency (at least to a first approx)
- Disadvantages:
  - Must peak jump to measure more than one isotope
    - Nearly always done by varying the magnetic field
  - Every peak jump must be accompanied by a delay time to allow both the magnet and the amplifier to settle, this delay can be significant
  - Since beam intensities will vary with time, isotopes can not be ratioed in real time

## Single Collector continued

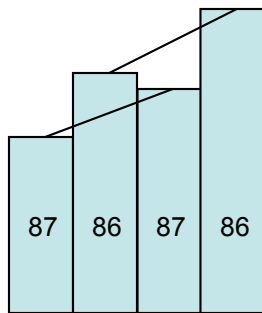

- Unfortunately we have no good way to know how the beam intensity changes with time
- Is it linear, some polynomial etc.
- Intensity behavior can change during a measurement
- This beam interpolation limits the precision of single collector measurements
- Precision is best for stable beams with little change in intensity and is improved by reducing the time between measurements of the isotopes
- This last point is limited by settling and measurement times
- For these reasons single collector measurements tend to be the least precise

# Multicollector-Static

- In order to get around some of the problems with a single collector, we can go to multiple collectors:

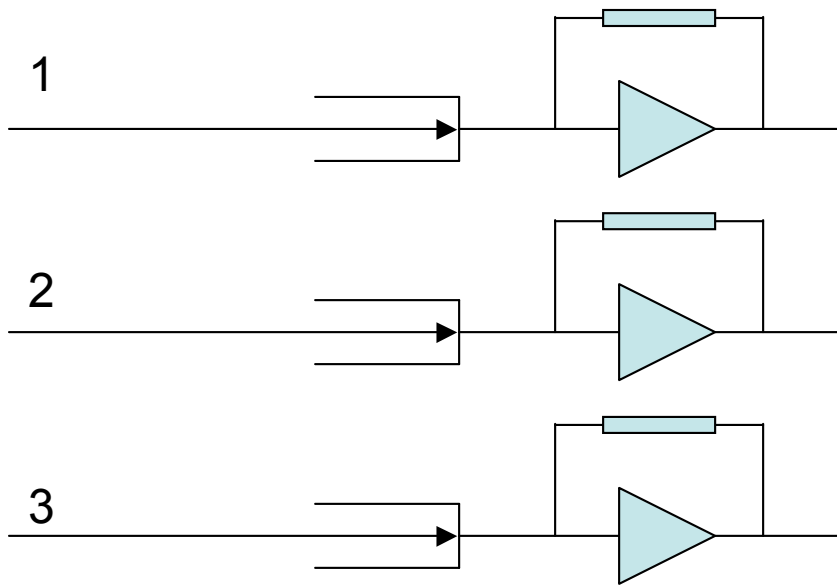

- In this example, three isotopes are measured simultaneously

- The assumption is that if beam intensity changes all of the isotopes will change proportionally

- Once an initial settling time is over there is no need to peak jump

- Cups can be aligned exactly to the beams

- Long measurement times are possible

- Fast

- Different detectors can be combined

# Multicollector-Static

- Disadvantages:
  - Detectors have to be movable and be able to be precisely aligned
  - Major disadvantage is that the amplifiers do not all behave the same mainly because

$$R_1 \neq R_2 \neq R_3$$

- The gain of each amplifier must be known precisely, however since we are ratioing we only need to know relative gains
- The amplifiers can be calibrated relatively by sending a constant current thru each amplifier

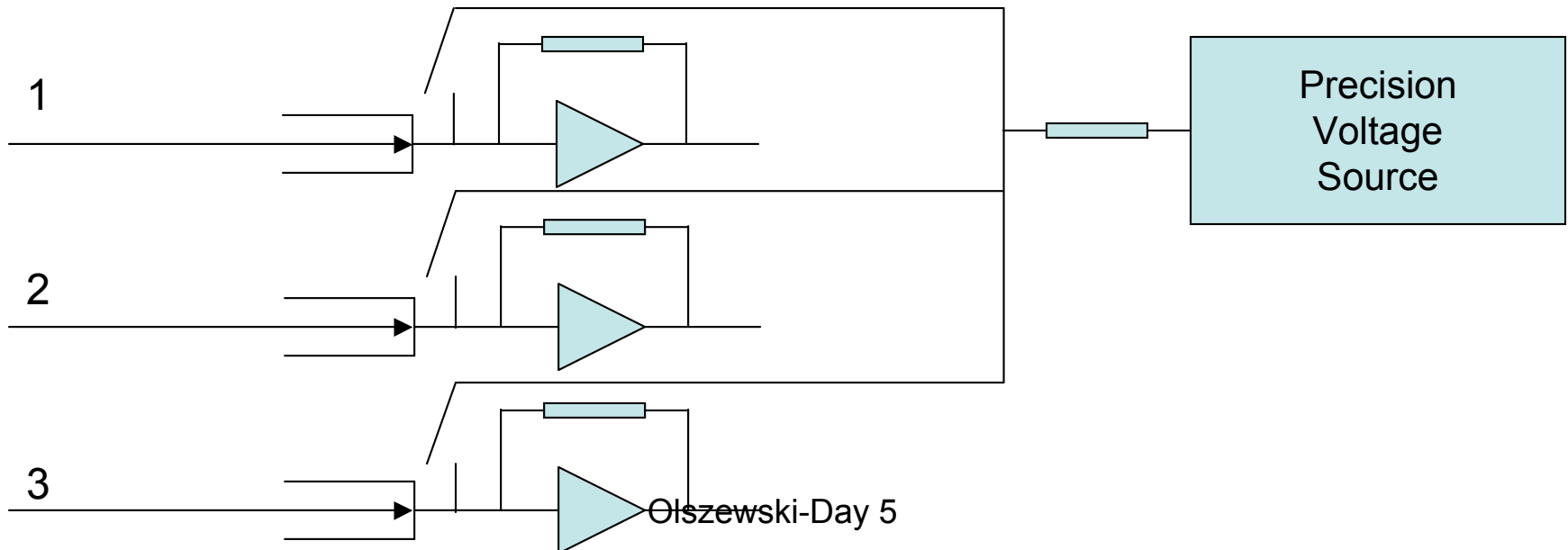

# Multicollector-Static

- In this way we can define a series of gain corrections,  $g$  for each cup relative to a reference cup (for example #1)
- These gain corrections can be measured very precisely (typically at the ppm level)
  - So for the example above:

$$g_1 = 1 \quad g_2 = \frac{V_1}{V_2} \quad g_3 = \frac{V_1}{V_3}$$

- To ratio two isotopes we would multiply the voltage output from each collector by the appropriate gain correction  $g$  and ratio:

$$\frac{I_2}{I_1} = \frac{V_2 \cdot g_2}{V_1 \cdot g_1} \quad \frac{I_3}{I_1} = \frac{V_3 \cdot g_3}{V_1 \cdot g_1} \quad \frac{I_3}{I_2} = \frac{V_3 \cdot g_3}{V_2 \cdot g_2}$$

- Static multicollector measurements are a big improvement over single collector measurements, however there are still some limitations

- Multicollector static measurements still do not take into account cup efficiencies
  - Efficiencies are hard to measure accurately and can account for significant variation (~100ppm) in relative cup response
  - So for example in the previous equations:

$$\frac{I_2}{I_1} = \frac{V_2 \cdot g_2}{V_1 \cdot g_1} \quad \text{should be} \quad \frac{I_2}{I_1} = \frac{V_2 \cdot g_2 \cdot e_2}{V_1 \cdot g_1 \cdot e_1}$$

Where  $e_1$  and  $e_2$  are the respective efficiency corrections (relative to cup #1) for each cup

- Amplifier gains may vary with time
- Multicollector dynamic measurements can get around these problems, at least for certain elements (e.g., Sr and Nd)

# Multicollector Dynamic Measurements

- Combines peak jumping with static measurements:

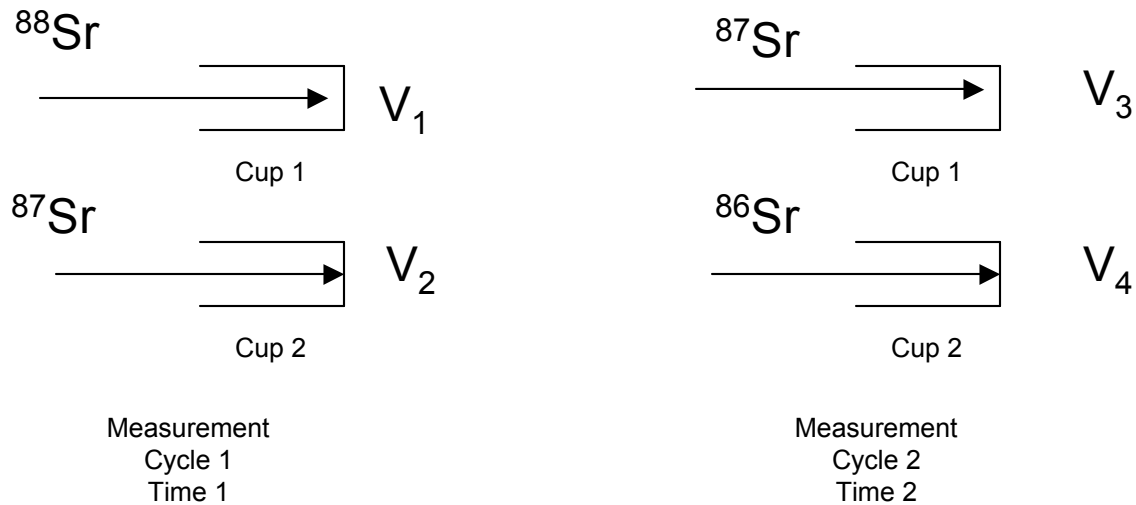

$$\frac{V_2 \cdot g_2 \cdot e_2}{V_1 \cdot g_1 \cdot e_1} \cdot \frac{V_3 \cdot g_1 \cdot e_1}{V_4 \cdot g_2 \cdot e_2} = \frac{V_2 \cdot V_3}{V_1 \cdot V_4} = \frac{{}^{87}\text{Sr}_{\text{cy1}} \cdot {}^{87}\text{Sr}_{\text{cy2}}}{{}^{88}\text{Sr}_{\text{cy1}} \cdot {}^{86}\text{Sr}_{\text{cy2}}} = R_c$$

# Multicollector Dynamic

- $R_c$  is an odd looking ratio, but it has some useful properties:
  - It is independent of the amplifier gains and cup efficiencies
  - It can be turned into a useful ratio by applying a fractionation correction:

$$\frac{{}^{87}\text{Sr}}{{}^{86}\text{Sr}} = \sqrt{\frac{R_c}{0.1194}}$$

- However, it also has some problems:
  - If gains or cup efficiencies change during the measurement cycles the ratio will be off
  - The fractionation correction is not quite correct and needs to be adjusted
  - Cups can not be aligned properly for both cycles, one beam will enter a cup off center, this could mean that one of the efficiencies does not cancel out exactly
  - Only really works for elements with internal fractionation corrections
- Multicollector dynamic measurement give the highest precision results

## Some way to get around some of the problems of multicollector analyses

- For static measurements we could get around the problem of gain measurements by switching amplifiers between cups during analyses
  - A simple example:

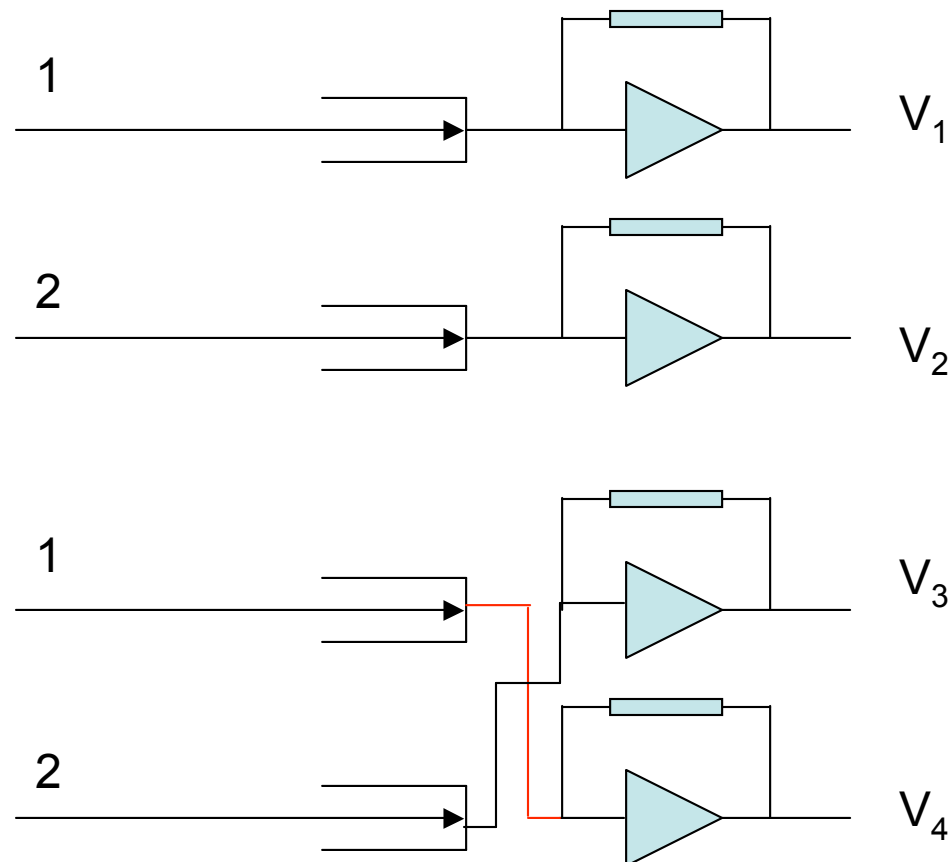

Olszewski-Day 5

## Amplifier switching

$$\frac{V_1 \cdot g_1}{V_2 \cdot g_2} \cdot \frac{V_4 \cdot g_2}{V_3 \cdot g_1} = \frac{V_1 \cdot V_4}{V_2 \cdot V_3} = \frac{I_1^2}{I_2^2}$$

- However, this does not take into account cup efficiencies

## Dispersion problems

- One problem with standard Multicollector dynamic measurements is the change in dispersion in peak jumping (i.e., the cups don't line up for all cycles)
- This can be gotten around by giving the mass spectrometer an independently variable dispersion.
- This is usually accomplished by placing quadrupoles (or higher order multipoles) before and after the magnet. This allows the positions and angles of the beam's entrance and exit to the magnet to be finally adjusted.
- Sometimes called "zoom optics" it allows the dispersion to be kept constant while the axial mass is changed.
- So during dynamic measurements the cup efficiency should not be affected by beams not perfectly aligned with the cups.

## Some brief words about ion measurement statistics

- The ion beams we are measuring are made up of discrete particles that arrive at the detector at some average rate  $\lambda$
- This average rate cannot go below zero and the variations of rate around this average are governed by the Poisson distribution

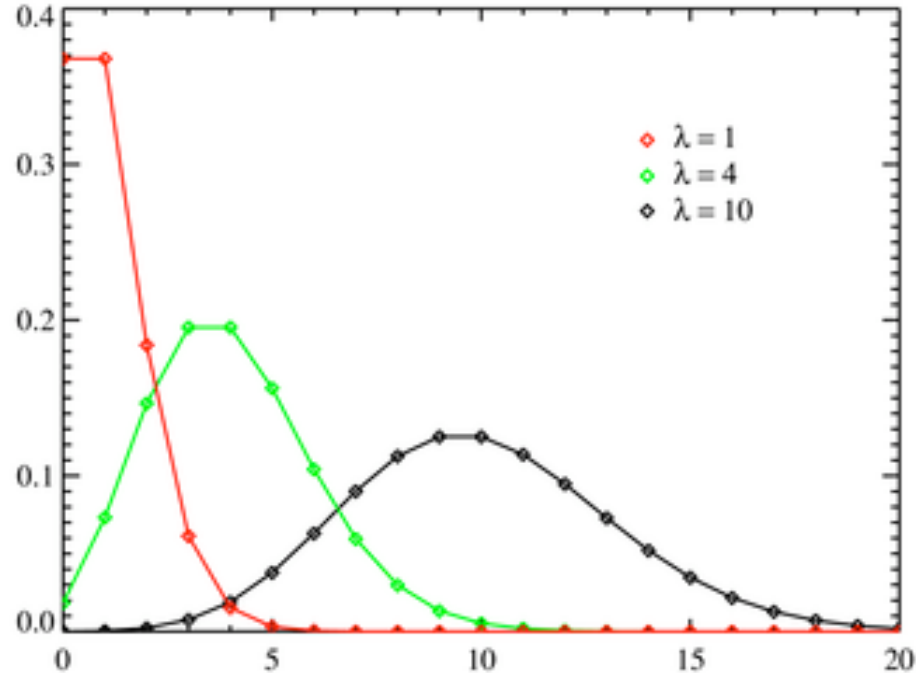

## Statistics continued

- A useful property of the Poisson distribution is that the variance  $\sigma^2$  is equal to  $N$ , the number of particles detected over a certain time.

- This means the fractional error in the measurement of an ion beam varies as

$$\frac{1}{\sqrt{N}}$$

- This puts a practical limits on how well we can measure an ion beam, to improve the measurement we need to measure more ions.
- As a practical example if we want to measure an isotopic ratio ( $\sim 1$ ) to 200ppm we need to know each beam to 100ppm, to do this we would need  $10^8$  ions, at a beam current of  $10^{-12}$  A this would take about 10s.
- However, to go down another factor of ten would mean collecting ions for 1000s.
- Ultimately then we are limited by the number of atoms in the sample chamber or on the filament and how efficiently we can generate ions.

# The Future

- How can we improve precision?
  - Increase the number of ions
  - Reduce the biases introduced by the measurement such as fractionation and detector bias.
- Increasing the number of ions
  - Dominantly a source issue, few ions lost once a beam makes it past the alpha defining slit
  - For thermal ionization, improving ionization efficiency at the filament is a major concern
    - Need to know more about the processes that occur on and near the filament
    - Up to now improving ionization efficiency has been more an art than a science with little more than general theory (e.g., the Langmuir equation) to guide us
    - Studying what goes on at the filament is difficult
      - Hard to measure what happens on or near the filament especially under the same conditions we run samples
      - The situation at the filament is inherently complex with 6 or more compounds on the filament that can generate dozens of different species on both the filament and the vapor phase above it.

# Ion Generation Efficiency

- We can also improve ionization efficiency by improving ionization after the fact i.e., after volatilization
  - We've already talked about multiple filaments
  - There are other techniques
    - Combining electron impact with thermal ionization

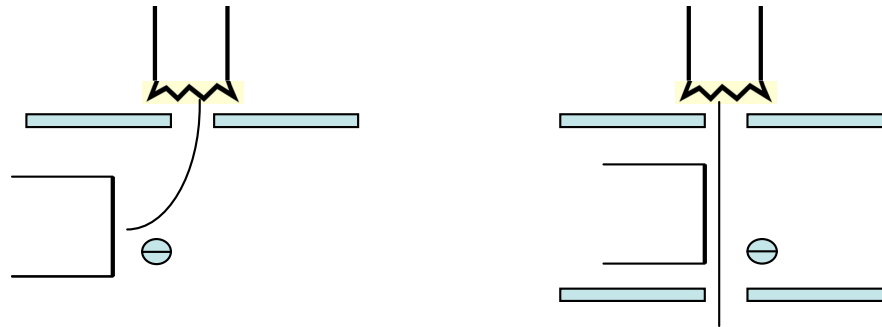

- RIMS-resonance ionization mass spectrometry, uses laser rather than electrons

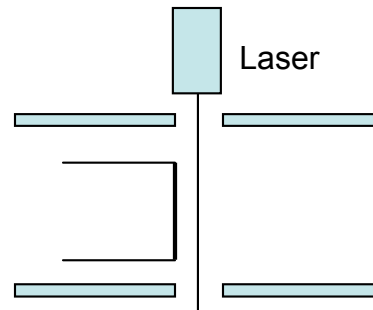

# Ion Generation Efficiency

- These techniques suffer from some drawbacks
  - Density of atoms in front of filament is very low, high electron or photon fluxes are necessary to get sufficient increase in ions
  - Such high fluxes can increase the energy spread of resulting ions
- There is one other advantage besides increased ionization efficiency
  - Energy of electrons or photons can be adjusted to enhance ionization of element of interest

# Fractionation

- Corrections for fractionation add errors to any measurement
  - In thermal ionization the major source of fractionation is volatilization of the sample from the filament
  - This fractionation is determined by
    - The mass and mass differences of the isotopes but unfortunately we have no control over this
    - Temperature
    - Surface parameters such as composition, filament material, matrix grain size, etc.
  - Higher temperatures of volatilization reduce fractionation
    - If the sample could be volatilized at high T without loss?

# The Analyzer

- There is probably not a lot we can do to improve things in the analyzer
  - Ion transmissions in most modern analyzers are ~100%
  - Higher order focusing doesn't gain much
  - Better vacuums can improve abundance sensitivity
    - Getting much below  $10^{-10}$  torr is difficult
    - Doesn't help much for elements like Sr or Nd where abundance sensitivity is not a problem

# The Collector End

- Modern collectors and detectors are highly efficient and sensitive
- However, biases and remaining inefficiencies need to be addressed
  
- Faraday Cups
  - Cup efficiency corrections
  
- Ion counting
  - Mass bias of conversion of ions to electrons
  
- Electronics
  - Non-linearities